

## Rubber wedge gate valve F4 Zacht dichtende schuifafsluiter F4



Design according to	Ontwerp volgens	DIN3352
Face to face according to	Afmetingen (L) volgens	EN558+1 14 Series
Flange drilling according to	Flensboring volgens	EN1092-2 PN10
Test according to	Test volgens	ISO 5208

Pressure Test to ISO5208/Druktest volgens ISO5208			
DN	Pressure rating (PN)	Hydro-Test Pressure (MPa)	
		Body/Huis	Seat/Zitting
40-300	10	1.5	1.1

## Rubber wedge gate valve F4 Zacht dichtende schuifafsluiter F4

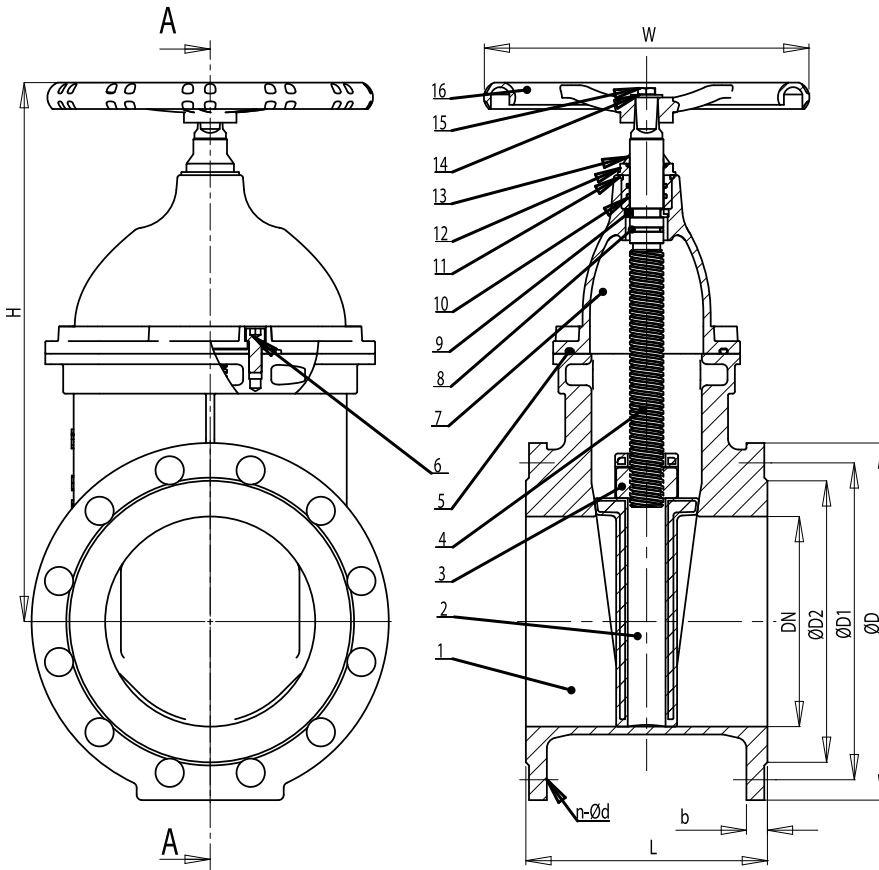

Material Specification			
	Part Name	Onder-deel	Material
1	Body	Huis	GGG40
2	Wedge	Schuif	GGG40 +NBR
3	Wedge Nut	Schuifmoer	Brass (messing)
4	Stem	Spindel	SS420 (RVS420)
5	Bonnet Gasket	Pakking	EPDM
6	Bolt	Bout	Carbon Steel
7	Bonnet	Deksel	GGG40
8	O Ring	O-ring	NBR
9	Washer	Sluitring	Nylon
10	O Ring	O-ring	EPDM
11	O Ring	O-ring	EPDM
12	Stuffing Nut	Moer	Brass (messing)
13	Dust Guard	Stofbeschermer	NBR
14	Bolt	Bout	Carbon Steel
15	Washer	Sluitring	Carbon Steel
16	Hand-wheel	Handwiel	Ductile Iron

Size/ grootte	L	D	EN1092-2 PN10		D2	b	H	W
			D1	n-d				
DN40	140	150	110	4-19	84	19	225	160
DN50	150	165	125	4-19	99	19	235	160
DN65	170	185	145	4-19	118	19	245	160
DN80	180	200	160	8-19	132	19	300	180
DN100	190	220	180	8-19	156	19	335	200
DN125	200	250	210	8-19	184	19	365	250
DN150	210	285	240	8-23	211	19	435	320
DN200	230	340	295	8-23	266	20	530	320
DN250	250	405	350	12-23	319	22	620	320
DN300	270	460	400	12-23	370	24.5	670	360